

# PART 8 INDOOR CYCLING – CYCLE BALL

Version 01.01.2018

## TABLE OF CONTENTS

	Page
<b>Chapter I TECHNICAL CONDITIONS.....</b>	<b>2</b>
§ 1 Type of sport .....	2
§ 2 Jury .....	2
§ 3 Match field and size.....	2
§ 4 Match field boarding .....	3
§ 5 Marking of the match field.....	3
§ 6 Goals.....	4
§ 7 Ball .....	5
§ 8 Clothing.....	5
§ 9 Cycle ball bicycles .....	6
§ 10 Defects / Changing bicycle.....	7
§ 11 Planning of the games .....	8
§ 12 Age categories / Game time and additional playing time.....	9
<b>Chapter II GAME RULES.....</b>	<b>10</b>
§ 1 General rules.....	10
§ 2 Kick off .....	11
§ 3 Start of the match .....	11
§ 4 Interruption / Whistling signal / Neutral ball.....	11
§ 5 Advantage rule .....	12
§ 6 Riding behind goal line / Permission to participate the game .....	12
§ 7 Scoring a goal .....	13
§ 8 Out ball.....	13
§ 9 Corner ball.....	14
§ 10 Goal defence .....	15
§ 11 Penalty area .....	15
§ 12 Free kick.....	16
§ 13 Penalty kick .....	17
§ 14 Whistle signals .....	18
§ 15 Complaints / Improper behavior / Unsporting behavior .....	18
§ 16 Injuries and suspension of players and teams .....	19
<b>Chapter III RESULTS / CLASSIFICATION BY POINTS / OBJECTIONS ..</b>	<b>21</b>
§ 1 Results .....	21
§ 2 Classification by points .....	21
§ 3 Ties / Final matches .....	22
§ 4 Penalty kicks .....	23
§ 5 Objections .....	24
<b>Chapter IV CLASSIFICATION OF RACES / UCI RANKINGS .....</b>	<b>26</b>
§1 Classification of races .....	26
§ 2 UCI Rankings .....	26
<b>Chapter V WORLD CHAMPIONSHIPS SET UP .....</b>	<b>28</b>

# PART 8 INDOOR CYCLING - CYCLE BALL

## Chapter I TECHNICAL CONDITIONS

### § 1 Type of sport

- 8.1.001** Cycle-ball is played in gyms or sport halls. The following surfaces are suitable for cycle-ball: wood, parquet, chipboard, triplex and synthetic floors. The game is played by two teams of two players.

### § 2 Jury

- 8.1.002** Cycle-ball competitions shall have a competition jury which consists of at least one commissaire, one time-keeper and a secretary. There can be several commissaires as well as linesmen. Linesmen must hold a commissaires license.
- 8.1.003** If no President of the Commissaire is appointed before the competition one should be appointed before the start of the competition. The President of the Commissaire is responsible for the running of the competitions or tournament in accordance with the regulations.
- 8.1.004** The commissaire is responsible for ensuring that the games are played according the regulations.
- 8.1.005** The linesmen have the task of following the entire game. They sit on the elongated goal line diagonal opposite the coaching zone. (See match field plan). They shall inform the commissaire and make observations by raising their hand. The Commissaire and linesmen assure communication and use, if necessary, hand signs. The commissaire may consult the linesman.  
*(text modified on 1.01.18)*
- 8.1.006** The time-keeper is responsible for the length of both halves and should indicate the end of each half with a clearly audible whistle. He shall stop the clock when determined by the commissaire. The time recorded by the time-keeper shall be definitive. He shall keep track of the time between the two halves and inform the commissaire after 1'45".
- 8.1.007** The secretary shall record the goals and make up the results list. The secretary or the hall speaker shall announce the result or other relevant information.

### § 3 Match field and size

- 8.1.008** The size of the field for international competitions must be 14 x 11 metres.
- 8.1.009** For national competitions however a minimum size of 12 x 9 metres is permissible.

- 8.1.010 On each side of the goal (elongated goal line) there must be a free zone of 0.60 metres over the whole width. The dimension is measured between the outer site of the elongated goal line and the boarding.
- 8.1.011 On each edge of the field there should be a free zone of at least 0.60 metres in width (distance between field boarding and wall or crowd).

**§ 4 Match field boarding**

- 8.1.012 Slanted wood or plastic boarding shall surround the entire field.
- 8.1.013 The boarding must have the following dimensions:  
Height 0.30 metres Angle towards horizontal surface 65° to 70° (see sketch below).  
The upper edge must be rounded and free of burrs.

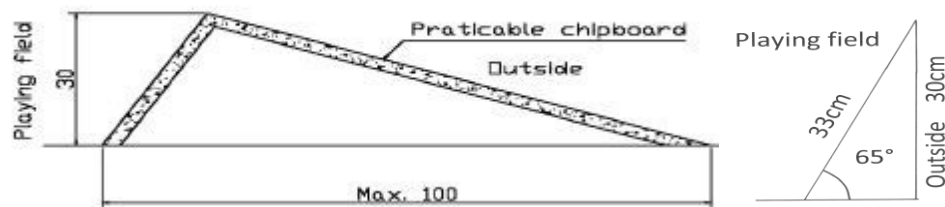

*(text modified on 1.01.18)*

- 8.1.014 The boarding must not be fastened to the floor.
- 8.1.015 Advertising may be displayed on the boarding.

**§ 5 Marking of the match field**

- 8.1.016 The field must be marked according the regulations and should be drawn up with clear lines and points as shown on the drawing below.
- 8.1.017 The width of the lines should be between 3 and 5 cm. The dots (points) should have a diameter between 10 and 15 cm.

8.1.018 All dimensions are external dimensions.

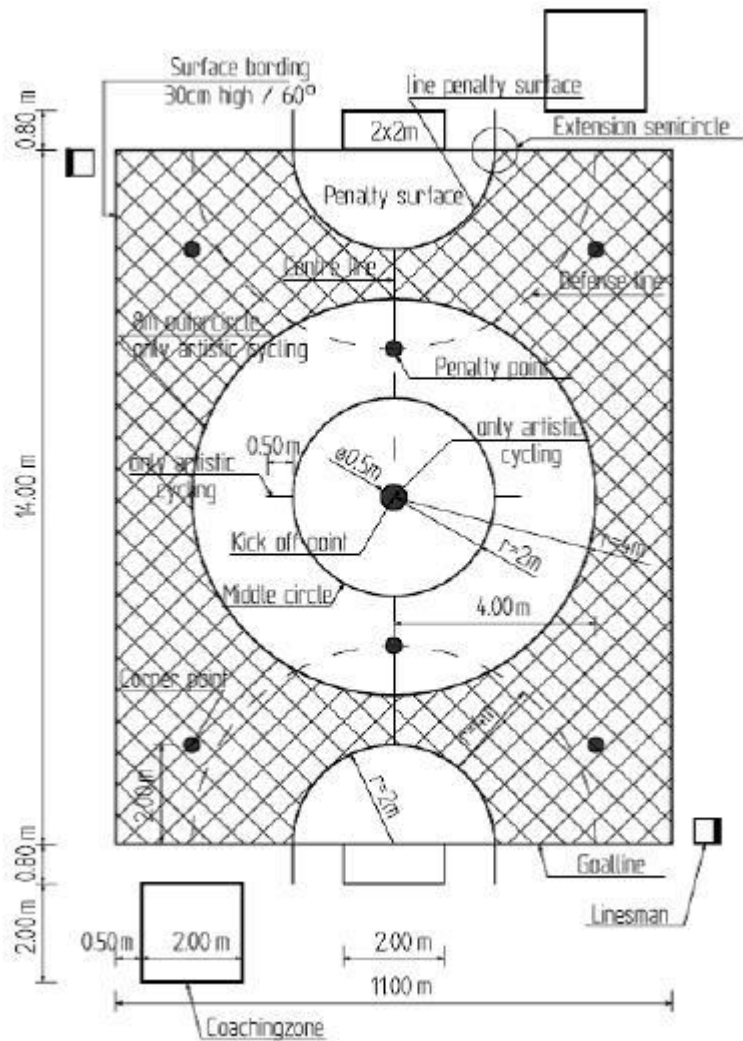

The 8 meter and 0.5 meter circles are only used for artistic cycling.  
Advertising is allowed in the shaded area as long as the surface conditions are equal to the none shaded area

**§ 6 Goals**

- 8.1.019 The goals must have the dimensions and construction as shown in the drawing below.
- 8.1.020 The goals must be fitted with a net (no wire). The net meshes must be capable of stopping the ball.
- 8.1.021 The goals must not be fixed to the floor.

**8.1.022** Cycle-ball goal

The internal measurements must be 2x2 metres. The diameter of the tubes must be between 3 and 5 cm. The fixing of the net must be constructed in a way that no injuries occur.

(the following sketch serves as an example)

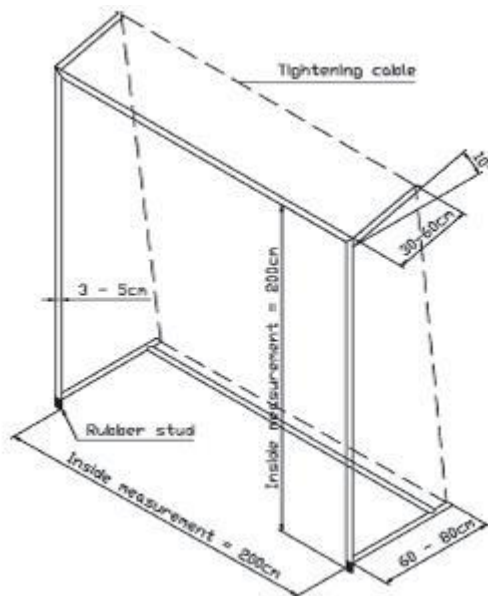

*(text modified in 1.01.18)*

**§ 7 Ball**

**8.1.023** A cycle-ball ball should have a textile surface and have a diameter between 17 and 18 cm. It must be spherical.

The weight shall be between 500 and 600 gram. It is the responsibility of the commissaire to decide if the condition of the ball is acceptable.

**§ 8 Clothing**

**8.1.024** Clothing shall consist of a jersey or T-shirt, shorts or cycling shorts. The top must be tucked into the shorts (to avoid accidents). A one piece skinsuit is permissible. Where cycling shorts are worn, the jersey may be worn on top of the shorts. Both team members must wear identical outfits.

**8.1.025** High-top sports shoes or ankle protections should be worn in order to protect the ankles.

**8.1.026** Knee-high socks or stockings must be worn. Shinbone protectors are recommended.

- 8.1.027** Gloves, sweat-band and cycling helmets are permitted.
- 8.1.028** No articles which might endanger other players may be worn. Piercings must be taped.
- 8.1.029** If both teams are dressed identically, one team should change their outfit. If neither volunteers the commissaire shall decide by the toss of a coin. If the team still refuses it shall be deemed to have lost the game by 5 goals to 0.
- 8.1.030** Advertising on sportswear is allowed as long as it meets the UCI regulations.

## § 9 Cycle ball bicycles

- 8.1.031** The bicycles used shall be constructed in accordance with following guidelines and dimensions:

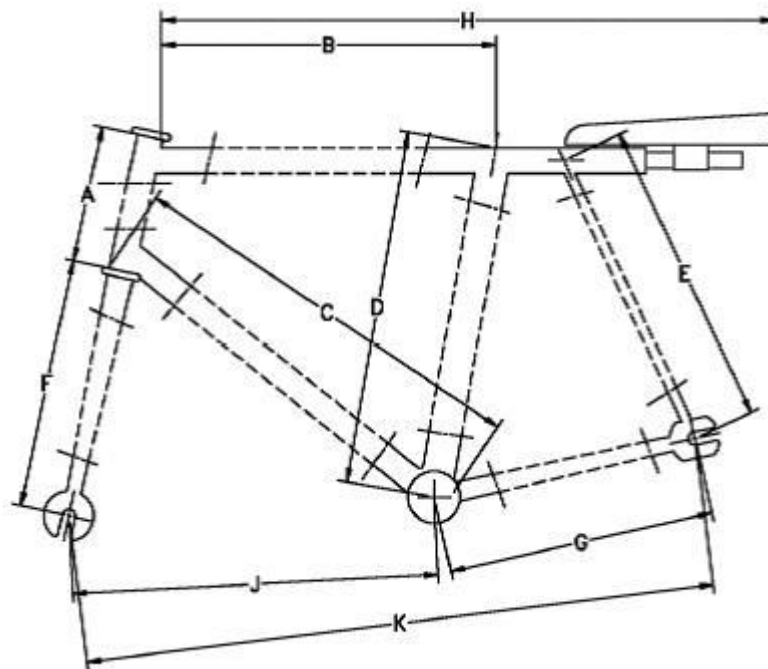

Dimensions:	A = 150 - 180 mm	B = 395 - 455 mm
	C = 560 - 610 mm	D = 500 - 550 mm
	E = 400 - 500 mm	F = 370 - 410 mm
	G = 360 - 410 mm	H = 815 - 960 mm
	J = 530 - 580 mm	K = 920 - 970 mm

For smaller bicycles these dimensions can be adapted in line with the wheel sizes.

Frame tubes may be round or oval. Curved tubes are allowed. The largest cross section of the tubes may not exceed 50 mm.

Tube fittings may not have reinforcements or supports which are bigger than the diameter of the ball itself.

New developments of bicycles which deviate from these norms may only be used with approval by the UCI.

- 8.1.032** Bottom bracket  
The distance between the lowest point of the front gear and the floor must be at least 220 mm +/- 2 mm.
- 8.1.033** Cranks  
The length of the cranks between center of the bracket axle and pedal spindle centre must be between 135 to 170 mm.
- 8.1.034** Handlebars  
The overall width of the handlebars may not exceed 380 mm. The ends of the handlebars shall be plugged to prevent accidents.
- 8.1.035** Saddle  
Saddles made of leather or plastic may be used. The maximum length shall be 300 mm and the maximum width 200 mm. The saddle should be fitted directly above the seat tube (an extension of the top tube of the frame). The highest point of the saddle must be above the top-edge of the horizontal frame tube, with a maximum of 100mm. Playing without a saddle is forbidden.
- 8.1.036** Pedals  
The pedals shall have rubber or plastic coverings over all exposed metal surfaces.
- 8.1.037** Wheels  
The diameter of the front and rear wheels shall be equal. In no circumstances shall the diameter be bigger than 26 inches or smaller than 20 inches. Only wheels with spokes are permitted; disc wheels may not be used. Wheel diameter front and rear may vary according to DIN norm 7168. i.e. for 26 " wheel +/- 3 mm.
- 8.1.038** Gearing  
For one complete turn of the cranks, the bicycle must moved at least 2.0 metres and no more than 3.20 m metres.
- 8.1.039** In general  
Dangerous equipment or any other aids like additional frame members, footholds etc. are not allowed. The front and rear axle ends and the chain tensioners must be well protected with enclosed nuts.

## **§ 10 Defects / Changing bicycle**

- 8.1.040** It is not permissible to continue playing with a damaged bicycle which might be dangerous to the other players. If the commissaire decides that the bicycle should be replaced because of the risk of injury to other players, the time will be stopped during the replacement.  
The player concerned shall continue to play immediately after having changed the bicycle. It is not permitted to wait until the bicycle has been repaired.

**8.1.041** A change of bicycle must be take place outside the match field area behind the player's own pro longed goal line (coaching area) without impeding the opponent. If the player does not live up to this he will be warned and in case of repetition a yellow card will be given. No coaches nor mechanics may enter the match field area (pass the match field boarding) during the match (unless the game is interrupted by the commissaire) nor may they interfere. If they do so, and the game will be influenced, the team shall be penalized with a penalty kick (4 meters).

**§ 11 Planning of the games**

**8.1.042** Prior to the competition each team should be informed on the enrolment of the competition i.e. split up into groups, sequence and timing.

**§ 12 Age categories / Game time and additional playing time**

**8.1.043** Cycle ball is divided into following age categories:

A.	Pupils league	up to 14 years	= under 15
B.	Youth league	up to 16 years	= under 17
C.	Junior league	up to 18 years	= under 19
D.	Young Elite league	up to 23 years	= under 23
E.	Elite league	from 19 years on	= from 19 on

The league depends on the year of birth, i.e. throughout the year of a player's 18th birthday he may play in the Junior league.

The leagues may if necessary, at the discretion of the national federations, be divided further in order to restrict the number of competitors or be combined where there are too few.

**8.1.044** The game (match) time depends on the different age categories:

A.	Elite and young elite	2 x 7 minutes
B.	Juniors	2 x 6 minutes
C.	All others	2 x 5 minutes

The match times can be reduced to a minimum of 2 x 5 minutes for certain tournaments or prequalifying rounds. The game time shall be taken to mean the two halves excluding a two minute break between halves.

**8.1.045** A game of decision shall comprise only a single half (without changing ends). 1 x 7, 1 x 6 or 1 x 5 minutes as per normal game time.

**8.1.046** The maximum time allowed to change ends may not exceed 2 minutes. Infractions of the rule should, after two verbal warnings, be penalized by an official warning to the team (both players).

Should the team ignore the official warning a second warning should be given and as a consequence the match be stopped.



- 8.1.047** Intentional time-wasting, match breaks or interruptions to the game attributable to one player or a team may lead to a stoppage after a warning by the commissaire. In such a case the commissaire announce via the time-keeper the additional time to be played (minimum of 20 seconds).

The remaining time must be clearly announced. Where the time is displayed electronically, a verbal announcement is not required.

The commissaire shall restart the game by blowing a whistle. He shall also whistle at an out ball, in order to give the time-keeper the precise signal.

- 8.1.048** If the finishing signal of the first half is given too early or too late, the second half shall be extended or shortened by the appropriate time to compensate.

In case of differences of opinion regarding the exact time remaining it shall always be the time keepers' time that is definitive. At half time and the end of the match it is the beginning of the timekeeper's signal which determines the end of play.

Any goal scored during an accidental extension of play shall not be cancelled. If the end signal is given too early, the remaining match time shall be played after an announcement of the remaining time. In case of a dispute concerning the time the commissaire shall decide after consulting the timekeeper.

## Chapter II GAME RULES

### § 1 General rules

- 8.2.001** Match field marking is neutral.
- 8.2.002** The players may drive the ball into the opponent goal by knocking the ball with the bicycles. One hand must be on the handlebars and one foot on the bicycle pedal. If such is not the case, the goal is not valid and the action cannot lead to a penalty or a corner. The game must continue with an out ball from the right corner marking.  
A ball which rebounds from a bicycle or the body of a player shall be considered as a valid kick. Headers are allowed.  
*(text modified in 1.01.18)*
- 8.2.003** Obstruction of the opponent (purposely riding into his bicycle, pushing or grasping), leaning on a goal-post or wall, leaning on the other player with hands or body, loud shouting (within the team, towards the coach, towards the opponent or any other person), objections (against a fellow player, opponent, commissaire, jury, coaches or public), shall be considered as against the rules and will be penalized.
- 8.2.004** Only the ball and never the opponent or his bicycles may be tackled. A player having the ball may only be tackled on the ball side.
- 8.2.005** Inside the match field or on the field boarding the ball may not be blocked or played back and forwards unless an opponent is obstructing.  
If a player is not obstructed by an opponent and fails to continue the game after the commissaire gives a warning it shall be considered a breach of the rules.
- 8.2.006** If the ball is stuck to the bicycle or to the body of a player, this causes a neutral ball.  
*(text modified in 1.01.18)*
- 8.2.007** It is not permissible to jump from the bicycle in order to catch an unreachable ball. In the event that this occurs repeatedly it shall be penalized with an official warning.
- 8.2.008** Coaching area  
Only two responsible persons of the team are allowed to take place on the chairs in the coaching area (see sketch point 8.1.018).
- 8.2.009** Time-wasting  
If a commissaire is convinced that a team is trying to keep the ball, and by doing this gain time, he shall inform the players with a hand signal (picture 4).  
The team shall have 20 seconds to attempt an attack. Should the team not finish the attack within this time, the commissaire decides on foul, which will be penalized by a free kick in the centre of the match field.

**§ 2 Kick off**

- 8.2.010** To start a game the commissaire shall toss a coin to determine which team shall start the game. The winning team shall begin the first half. The other team shall start the second half.  
After each goal the team against which the goal was scored shall have the right to restart the game.

**§ 3 Start of the match**

- 8.2.011** The ball shall be placed on the centre point at the beginning of a game and after each valid goal scored.
- 8.2.012** At the start of the first or the second half and after each goal the players may stay wherever they want in the field except in the centre circle and in the penalty area of the opposing team.
- 8.2.013** After the starting whistle the attacking team may ride into the centre circle and move the ball. The ball may be touched more than once by the first player. The defending team may enter the centre circle as soon as one of the attackers have touched the ball.
- 8.2.014** If a member of the defending team enters the centre circle and remains there at starting of the game (touch of the ball), the defender will be penalized by a free kick on the nearest place of the defenders goal (center line). The commissaire may optionally give advantage to the attacking team if the attack can be continued without delay.

**§ 4 Interruption / Whistling signal / Neutral ball**

- 8.2.015** The start of each half time and any other interruption shall be given by whistle by the commissaire. On each goal the commissaire shall blow a long whistle. Half time and the end of the game shall be given by a signal from the timekeeper. The commissaire shall whistle to confirm the end of the first half and the end of the game with two long whistles but the definitive signal is that from the timekeeper.
- 8.2.016** The commissaire must interrupt the game in the event of:
- Any breach of the rules.
  - The ball leaving the match field.
  - A goal.
  - The ball hitting the ceiling.

The commissaire must interrupt the game and stop the time by giving a hand sign (according to picture nr 6) and a short whistle in the event of:

- A player, the jury or other persons have to be verbally notified.
- The score or time is not clear.

- A player is injured or an injury is suspected.
- Official warnings
- Disqualification.
- The match field being not set up properly or in line with the rules.

*(text modified in 1.01.18)*

**8.2.017** The time shall not be stopped in the event of a problem to bicycle equipment or incorrect sportswear.

An exception shall be made if any scattered object is on the match field or if sportswear has become indecent.

**8.2.018** If the match has been interrupted for some reason and the ball has not left the match field, or no offence against the rules has been noticed, the game should be continued by means of a neutral ball. A neutral ball shall be given in the event that the ball hits the ceiling or any other foreign object. In all cases the neutral ball shall be given on the centre point of the field. The players have to wait outside the centre circle and can enter the centre circle and touch the ball after the commissaires whistle. A player may touch the ball several times.

## **§ 5 Advantage rule**

**8.2.019** Since a player who commits an offence should never gain an advantage from the situation; the commissaire may decide not to interrupt the game and to give the advantage to the none-offending team although the other team has committed an offence.

If advantage is given, the commissaire shall give a signal by showing the direction of the game and to say "Go on" (see picture number 2). If the advantage is lost during the same game situation, the commissaire may decide to withdraw the advantage by interrupting the game in favour of the team which is not at fault.

*(text modified in 1.01.18)*

## **§ 6 Riding behind goal line / Permission to participate the game**

**8.2.020** If during a match (except at interruptions or at half time) a player falls, touches the floor, leans against an other player, leans against the wall, leans on the match field boarding, leans on the ball or the goal that player shall not be permitted to continue playing.

**8.2.021** To become eligible to play again, the player concerned has to ride or walk immediately behind his goal line and re-enter the match field on the same side. He must cross the goal line with one wheel outside the penalty area.

**8.2.022** If a player who is not allowed to participate in the game disrupts the game by lying down or standing, or by covering or holding his opponent or touching the ball with the intention of disadvantaging his opponent, the player shall be penalized with a free kick.

*(text modified in 1.01.18)*

- 8.2.023** If a player in his own penalty area touches the floor or leans against the goal, he must leave his penalty area immediately and cross the goal line in order to get permission to return to the game.

The player concerned has to cross the goal line in such a way that both wheels have left the penalty area and at least one wheel has crossed the goal line outside the penalty area.

- 8.2.024** Should an ineligible defender remain in the penalty area, a penalty (4 m.) kick shall be given if he touches the ball or impedes his opponents.

- 8.2.025** Offences against riding behind the goal line in the field shall be penalized with a free kick, in the penalty area with a penalty kick.

## **§ 7 Scoring a goal**

- 8.2.026** A goal shall be valid if the ball passes the goal line between the goal posts.

If the ball rolls on the floor the central contact point of the ball has to pass the back of the goal line.

The same principle shall apply to any ball in the air.

The goal is still valid even if the player falls off his bicycle after striking.

- 8.2.027** If a goal is being moved from its normal position during the game and a goal is scored, the determining item shall be the imaginary line between goal posts and not the floor marking. If the ball passes an imaginary line between the goal posts, the goal shall be valid.

- 8.2.028** A ball struck or deviated into a player's own goal shall count towards his opponent's score.

- 8.2.029** After a disallowed goal the ball shall be put on the right corner point and may be played by the defending team.

## **§ 8 Out ball**

- 8.2.030** If the ball leaves the match field over the long sidelines on the ground or in the air the match should be interrupted. The commissaire should collect the ball and place it 1 meter away from the sideline where the ball crossed. The team which did not put the ball out of play shall serve. The opponent must keep a distance of at least 2 meters from the ball and the commissaire shall allow the game to restart without any signal. If the opponent is less than 2 meters from the ball a free kick shall be given.

- 8.2.031** If the attacking team kicks the ball over the goal line outside the goal, the ball shall be put on the corner marking on the side where the ball went out. When the ball crosses the goal line the commissaire shall whistle. The defending team may restart the game without any signal from the commissaire.
- 8.2.032** An out ball may be touched several times by the serving player.
- 8.2.033** Should the half time or match time be finished the out ball regardless on the goal line or sideline is not executed.

## **§ 9 Corner ball**

- 8.2.034** If a ball is hit by a defending player, or comes off the defenders body or bicycle and crosses his own goal line, the commissaire shall whistle to stop the game and a corner will be awarded to the opponent.

A corner ball must be served from the corner point after a whistle signal from the commissaire.

All players should be on their correct position.

- 8.2.035** For the execution of a corner ball the defending player (goalkeeper) should have both wheels in his penalty area while his partner should stay behind the centre line on the opposite side of the corner point. Outside the dotted defense line he should keep a minimum distance of 4 meters.  
After the ball has been touched the defenders are allowed to leave their position. The ball is considered as being hit as soon as the ball is touched by the attacking player after the whistle from the commissaire. The second attacking player is not allowed to be in the defending teams' penalty area nor on the opposite side between the penalty area and the dotted defence line.  
The middle line between the penalty spot and the centre of the penalty area is considered as being a "wall" even in the penalty area. This means that this "wall" may not be passed by neither the offence nor the defensive player prior to the serve of the corner. This does not only concern the floor contact area of the wheel but also the foremost point of the wheel, bicycle or body.
- 8.2.036** The corner ball may be touched only once. A served corner ball being bounced on the goal frame or the boarding may not be touched for a second time by the serving player as long until some other player has touched the ball.
- 8.2.037** A corner must be executed even if the match time (half and full time) is over. (last kick)  
A goal by last kick shall only count, if the goal is scored directly or because of a mistake at the goalkeeper's defence.  
During execution of a last kick the other players may not interfere, not even pretending an action.
- 8.2.038** A last kick corner may not lead to a further corner.  
If the corner is not defended according to the rules a penalty kick shall be awarded and executed.

**§ 10 Goal defence**

**8.2.039** All offences against the rules of the goalkeeper within the penalty area should be penalized by a penalty kick.

**8.2.040** The goal defence can be executed by either player of the team. The goalkeeper is entitled to use one or both hands to defend his goal as long as both wheels are in the penalty area, both feet are on the bicycle pedals and he is eligible.

**8.2.041** A ball caught by the goalkeeper within the penalty area may not be thrown out further than the dotted defence line and the ball must touch the floor within 3 seconds. The ball may not be thrown towards the co-player (the head, the body or the bicycle) as long as the he is outside the defence line.

Should a beaten off ball bounce off in front of the defense line and then roll over this line, no offence has been committed.

**8.2.042** The ball may be beaten away with the hands (even a double beat), even if it passes the defense line as long as the ball has not been caught first with one or two hands.

**8.2.043** A ball that was beaten off with hands and continues to roll, either inside or outside the defense line, may only lead to a goal if it was defended correctly and touched by another player.

Thus a direct goal from the hand cannot occur, except for an own goal resulting from incorrect defense from the goalkeeper.

**8.2.044** If the goalkeeper catches the ball he may bounce it once on the floor and catch it again. Then the ball must be thrown or kicked.

**§ 11 Penalty area**

**8.2.045** During the game only one player of the team may be in the penalty area and act as goalkeeper. A player is considered as being in the penalty area as soon as a part of his bicycle or body touches the floor in the penalty area.

**8.2.046** At any time only one player from the attacking team may be in the opponents' penalty area providing the ball is in the penalty area. A player is considered as being in the opponents' penalty area as soon as a part of his bicycle or body touches the floor in the penalty area.

If a player gains possession of the ball, on the floor, from inside the penalty area although he stays outside the penalty area he shall be considered as being inside the penalty area.

The elongated line from the penalty area behind the goal line is not considered as part of the penalty area.

- 8.2.047** If a ball is kicked away from the penalty area so that the attacking player is left inside the penalty area without a ball, this shall not constitute an offence as long as the ball rolls away from the goal and the goalkeeper is not hindered by the attacker in any way.  
Should the attacking team gain the ball, no advantage shall be given but considered as “offside”. The attacking player in the opponents’ penalty area shall regain his eligibility if he leaves the penalty area.
- 8.2.048** If the commissaire decides that there has been a breach of the rules, this offence will be penalized with a free kick from the centre of the penalty area at the beginning of the middle line (off side point).
- 8.2.049** If both attacking players are in the opponents’ penalty area, even if the ball is inside, it is considered as an offence to the rules and be penalised with a free kick on the off side point. The ball has to be kicked after the whistle from the commissaire by one of the defending players. He may touch the ball only once.
- 8.2.050** The goal area is considered as being part of the penalty area.

## **§ 12 Free kick**

- 8.2.051** A free kick is granted for offences committed outside the penalty area. The ball is placed at the point the offence happened, but at least one meter from the boarding. After the defender has reached a distance of at least 4 meters from the ball, the commissaire whistles. Should this distance not be kept, before the ball is kicked, a new offence against the rules shall be given.

If the free kick is less than 4 meters from the goalkeeper the following is obligated: Before the whistle, the defending goalkeeper has to stay in the penalty area parallel to the goal line, and no more than 15 cm in front of his goal line. He may leave this position only after the ball is has been hit by his opponent.

A free kick may only be served once; prior to a second serve, the ball must be touched by another player or his bicycle. A player shall not be eligible for a second serve if the ball touches the goal frame or the field boarding.

- 8.2.052** A free kick must be served even if the normal time (half and full time) is over. There will be a “last kick”.

A last kick results in a goal, if kicked directly on the goal or through a defensive error.

A last kick will not lead to a corner. During execution of a one shot the other players may not interfere, not even pretending an action.

Offences against the defense rules must be penalized with a penalty kick.



**§ 13 Penalty kick**

**8.2.053** A penalty is the punishment for offences committed within a player's own penalty area.

A player is considered to be within his own penalty area as soon as part of his bicycle or his body touches the floor of the penalty area even if the offence is done outside the penalty area.

Offences outside a player's own penalty area:

- A. If a player stops his opponent by a "serious" fault e.g. tackles or pulls the opponent from the bicycle
- B. If a player who is not allowed to participate in the game stops an opponent or the ball by walking, running, jumping or using the bicycle to avoid an attack. (leaving a stable position)
- C. Playing the ball purposely by hand outside the penalty area.
- D. Purposely pushing or pulling the goal away by a defending player or his coach or teammates.
- E. When a player does not hold his bike and on purpose holds or deviates the ball or obstruct the opponent.
- F. When a player is ready to kick the ball in an empty goal and is obstructed by his opponent.

**8.2.054** At a penalty kick all players with exception of the goalkeeper and the player kicking the ball should take up position behind the penalty spot. After the whistle the ball has to be directed directly towards the goal. The other two players may in no circumstances interfere.

The defending player (not the goalkeeper) must keep a distance from 4 meters towards the ball and has to be on the other side from where the attacking player is going towards the ball. Both non active players can come into the game as soon as the ball has been touched.

If the defending player breaks the rule a new penalty kick shall be given. If the second attacking player commits an offence he will be penalized by a free kick.

**8.2.055** A penalty kick can only be served once and must be kicked directly towards the goal. Riding past the ball and "braking" during the attack is not permitted. Offences hereto are penalized by a free kick.

The rebound of the ball from the goal post does not entitle the penalty kicker to a second serve.

**8.2.056** The defense against a penalty kick must be such that the goalkeeper prior to the whistle signal is situated with front and rear wheel parallel to the goal line and maximum 15 cm in front of it.

The defender may leave this position from the moment on the ball has been served.

Offences against are penalized by a new penalty kick.

**8.2.057** A penalty kick must be executed even if the half or full time has been reached. If the finishing signal sounds before the execution of the penalty kick, the commissaire will give a whistle signal to serve if the goalkeeper is in position. If

the finishing signal sounds when the ball is in the air but has not past the goal line, the goal does not count and the penalty kick will not be repeated.

A penalty kick goal executed after the end of game time will only be counted if the ball goes into the goal without help of the other players not involved in the execution of the penalty kick. The players directly involved in a penalty kick are the serving player and the defending goalkeeper. The serving player may not kick a second time if the ball rebounds from the goal post or goalkeeper.

A penalty kick correctly executed after regular time which crosses the goal out line will not lead to a corner ball.

If a penalty kick has been defended incorrectly and no goal has been scored a new penalty kick shall be given.

Should the penalty kick not be executed correctly while served after the regular time, e.g. like stopping, braking during the attack etc, there will be no further punishment. The penalty kick shall not be repeated and the game is over.

## **§ 14 Whistle signals**

**8.2.058** At the start of the half, a corner, a penalty kick, a free kick and a neutral ball the ball will be put into play after a whistle signal.

A corner ball, penalty kick and free kick can only be served once, after which the ball has to be touched by another player or his bicycle. After serving all other players are allowed to continue playing.

**8.2.059** If any ball which can only be served after a whistle signal is served prior to that signal, it shall be repeated.

**8.2.060** If the ball goes out of play during the match, a whistling signal is given to interrupt the game. The ball will be put by the commissaire on the spot that the ball left the match field. If the ball went out on the extended goal line the ball shall be placed on that corner spot on the side where the ball went out. Under no circumstances shall a whistle signal be given to restart the game.

The release of the ball does not depend on the security of the goal; it is playable immediately.

**8.2.061** In case of any offence, the commissaire must very clearly show against which team a free kick or penalty kick is given. The same procedure has to be followed for corner ball and out balls.

**8.2.062** The signals for free kick, penalty ball, corner ball and neutral ball shall be given as soon as all players have taken their positions at the required distances from the ball.

## **§ 15 Complaints / Improper behavior / Unsporting behavior**

**8.2.063** In the event of improper behavior of a player or team the commissaire should warn the concerned party by a verbal warning or a yellow card.

Improper behavior shall include cases when:

- One player or more players repeatedly criticizes a decision taken by the commissaire.
- A player seeks to argue with his opponent, partner, the tournament jury and/or spectators.
- Repeated unjustified protest by raising one hand.
- Repeated on purpose violations of the rules.
- Quitting the game or leaving the match field without justified reason.

*(text modified in 1.01.18)*

**8.2.064** Should the coach of a team repeatedly disrupt the progress of a match or repeatedly criticize a commissaire, the commissaire may sanction the coach with a yellow or red card. In the case of a red card, the coach must leave the hall.

*(text modified in 1.01.18)*

**8.2.065** If warnings are being issued the match must be interrupted, the time stopped (picture 6) and the concerned person(s) shown the yellow card. The commissaire must inform the jury of the reason of this yellow card. The jury must announce the warning and the remaining match time. With electronic time panel the time announcement has not to be given. After this the commissaire can continue the game.

**8.2.066** If the behavior of a player is cause for a second yellow card during the same game, the commissaire must act as per article 8.2.066.

The referee will then show him the red card and the concerned player has to leave the match field.

The result of the game will be 5:0 against the team in question, unless the score of the opponent is already higher.

**8.2.067** In case of extreme unsportmanship the concerned player may be sent off without prior warning and should receive directly the red card.

Unsporting behavior includes:

- A player stopping or holding back his opponent violently by e.g. running him down or pulling him off his bicycle (emergency stop).
- Violence against players, jury, commissaires or public.
- Insulting the commissaire.
- Throwing or kicking the ball at the commissaire.
- Purposely riding the bicycle towards or pushing the commissaire.

In the above cases the game will be stopped and the game lost 0:5 unless the opponent's score at that point is better.

**8.2.068** A warning shall always be followed by a yellow card.

## **§ 16 Injuries and suspension of players and teams**

**8.2.069** In case of non-attendance or late arrival or the elimination of a team the following rules are applicable.

- 8.2.070** Any game where both players are not on the match field at the starting signal of the game shall be considered as lost with a score of 0:5.
- 8.2.071** The jury is permitted to change the order of play where a team arrives late due to force majeure.
- 8.2.072** A team which arrives late at the contest hall may play their remaining matches if not all games of his group have been played. The matches already missed shall however still be considered as 0:5 defeats.
- 8.2.073** If a team stops competition by not appearing in a tournament or series, all games shall be deemed lost by 0:5 goals.
- 8.2.074** Should a team or a player be suspended under article 8.2.067 the player or team may start the next game.
- 8.2.075** If a player is suspended according art. 8.2.068 he may not play in the next two games. He can be replaced by a substitute.  
In the event of very serious infractions disciplinary procedures can be started against the person concerned in line with chapter 12 "Discipline and Procedures" of the UCI Regulations
- 8.2.076** If both players are suspended under article 8.2.068 all games for this team should be abandoned.  
The team shall be excluded from rankings and prizes.
- 8.2.077** If both players are suspended during a championship series or ranking series under article 8.2.068 they retain the points already scored. The remaining games shall be lost with a score of 0:5.
- 8.2.078** If a team drops out of the tournament due to injuries, illness or lack of a substitute, the team's results up to that point shall be counted. The remaining games shall be lost 0:5.

**Procedure in case of injuries**

- 8.2.079** If a player indicates an injury by raising his hand the commissaire may stop the game.

If the commissaire can not clearly identify the injury, he has to give a signal by raising his hand showing that he noticed his signal but there is no obligation to stop the game. The commissaire must be sure that the wound is not feigned for diverse reasons such as a damaged bicycle. In the latter case, there is no interruption of the game.

If the commissaire comes to the conclusion that there is a real injury, he has to interrupt the game. He gives by hand the signal to the responsible person (coach) or and to the doctor that he can enter the field. Only one responsible person, a doctor or another person belonging to the medical service is authorized to enter on the field of play.

If the responsible person or the doctor enters the field before the commissaire gives the signal by raising his hand, the team concerned shall be punished with a penalty kick (4 meters).

During time interruptions due to injuries, bicycles can be exchanged and or repaired outside the boarding (coaching zone)

The linesmen shall follow these actions very scrupulously in order to recognize any irregularity or to clarify the situation.

- 8.2.080** If a player is seriously injured and has to leave the field, the substitute player may replace him immediately. The game shall continue within the next 5 minutes (time of interruption). In some special cases, the commissaire may increase the time of interruption to a maximum of 10 minutes.

The injured player can, after having been replaced by a substitute, continue the tournament after having informed the commissaire or President of the Commissaire. If the same player gets injured for the second time he may not participate in the tournament any longer.

One player from the original team must always remain in the team. None of the other players are allowed to leave the field.

During the injury-interruption, responsible members of the adversary team are not allowed to enter the field. They shall stay behind the boarding surface.

## **Chapter III RESULTS / CLASSIFICATION BY POINTS / OBJECTIONS**

### **§ 1 Results**

- 8.3.001** Every valid kick into the goal shall be counted as being scored.
- 8.3.002** After each valid goal and after each half the score should be clearly announced.
- 8.3.003** The goals scored must be recorded as they happen by the secretary of the tournament jury.  
The scoreboard should display the actual score to players and spectators.
- 8.3.004** The winner of a game is the team who score the most goals. In the event of equal scores the match shall be drawn.

### **§ 2 Classification by points**

- 8.3.005** For each game won the winners are awarded 3 points. For a drawn game both teams are awarded 1 point. The losing team is awarded no points.

- 8.3.006** The result for a tournament or championship is calculated by summing up all the points scored by each team.
- 8.3.007** If qualifying matches etc. are played, the points awarded for them are only calculated for that particular round. It is however permissible to add points from the preliminary or semi-finals together if participants are notified in advance.
- 8.3.008** The winner shall be the team with highest points total.

**§ 3 Ties / Final matches**

- 8.3.009** Days of matches, rounds of a competition over several days  
In the event of a tie on points, goal difference shall determine the ranking. Goal difference is calculated by subtracting goals scored against the team from the goals scored by the team. The goal difference may be positive, negative or zero.

If two teams are still tied on goal difference, the team with the highest number of goals scored shall be given the higher ranking.

Should the result remain tied, a play-off under article 8.1.046 should be arranged if the result determines the next round or promotion or relegation between divisions.

- 8.3.010** Final round in championships, national and international competitions  
In the event that two teams are tied on points for first place a playoff will be played under article 8.1.046. If the result of this game is also tied, the result shall be determined by penalty kicks as per paragraph 4.

Should more than two teams be tied for first place, the results of games between these teams shall be considered. The two highest in this ranking shall play a play-off match under article 8.1.046. Should this match be drawn the result shall be determined by penalty kicks under paragraph 4.

If more than two teams are equal on points after the above calculation the two teams with the best goal difference shall be placed first and second. In the event of a tie on goal difference the team with the highest number of goals scored shall be the winner.

The top two teams shall play off as per article 8.1.046 to determine the winner. Should this match be drawn the result shall be determined by penalty kicks under paragraph 4.

If more than two teams are still tied after considering goal difference, the result in the total final round shall determine the leading team. The two teams with the highest goal difference, if it should be the same between more than two teams, and the highest total number of goals scored shall play off as per article 8.1.046. Should this match be drawn, once again the result shall be determined by penalty kicks under paragraph 4.

If and only if more than two teams in this final round are tied on points and the top two teams cannot be determined as described above, then all these teams shall play off against each other as per article 8.1.046, etc.

The order in which these matches are played shall be determined by draw, as well as the right to serve.

The team with the most points from the playoff matches shall be the winner.

If two or more teams are equal in points after the play-offs, then penalty kicks shall determine the winner as per paragraph 4.

In each penalty kick competition the winners shall be awarded three points, and the loser no points. The team with the highest points total shall be the winner.

In the event that the teams are still tied on points the winner shall be the team with the best goal difference of the penalty kick decision and should that not be decisive the team with most goals scored. In the event of a tie further penalty kicks shall be taken until the winner is known.

The teams taking part in the play-offs shall be ranked after the play-offs are completed. The other teams shall be ranked according to points scored, goal difference and total goals scored. Should that method result in a tie, the matches between the tied teams shall be considered. Should that fail to break the tie, a play-off will be played should the result be critical in determining which team progresses to the next round or is promoted or relegated in a division.

- 8.3.011** *World and continental championships / world and continental cups*  
During these competitions the procedure in article 8.3.010 shall be followed for all medal places.

Teams not in a medal-winning position shall be classified by points, goal difference and goals scored. If two teams are still tied then the direct result between them shall be counted. If that game was a draw then a play-off must be played.

#### **§ 4 Penalty kicks**

- 8.3.012** In the event that two or more teams have equal points after deciding matches, penalty kicks shall be taken. In the first penalty kick round each player of the team has to attempt two penalty kicks on the opponent's goal.

- 8.3.013** The commissaire shall determine which team goes first by draw. , Each team shall then announce which player is to kick first, and then they will alternate. The players must serve their kicks in the same order towards the goal as their opponent.

The goalkeeper may be changed within the team.

- 8.3.014** The winning team shall be awarded three points.

If after the first round of penalty kicks does not produce a result, the teams it shall continue to alternate kicks until a result has been reached.

**§ 5 Objections**

**8.3.015** Objections against facts and decisions by the commissaire may not be submitted.

No objections may be made to the allocation of commissaires to games.

**8.3.016** Objections against the groupings for a series or group, the arrangements for or order of matches must be submitted as soon as they are received.

**8.3.017** Objections concerning the field of play, ball, goals etc. must be submitted prior to the matches.

Handsigns Commissaire

Picture 1 - Goal



Picture 2 - Advantage



Picture 4 - Time wasting





Picture 5 – Goal not valid



Picture 6 - Time out



## Chapter IV CLASSIFICATION OF RACES / UCI RANKINGS

### §1 Classification of races

#### 8.4.001 Category A events

- minimum of 4 participating nations;
- minimum of 8 participating teams;
- one president, UCI international commissaire;
- two UCI or national commissaires from two different countries;
- results list signed by the president of commissaires' panel to be sent to the UCI within 48 hours, at the organizers expense (stamped envelope handed to the president, or sent by fax or e-mail).

Note: Any organizer who, when registering his event, asks to be put in Category A and is unable to fulfill all the requirements, will not be able to register any Category A events for the following two years. However, in order not to penalise the competitors, category A points will be awarded.

*(article introduced on 1.01.05; text modified on 1.01.13)*

#### 8.4.002 Category B events

- minimum of 2 participating nations;
- minimum of 5 participating teams;
- one president, UCI international or national commissaire;
- one UCI or national commissaire;
- results list signed by president of commissaires' panel to be sent to the UCI within 4 days, at the organizers expense (stamped envelope handed to the president, or sent by fax or e-mail).

Note: If the organizer is unable to secure the participation of two nations no UCI ranking points will be awarded.

*(article introduced on 1.01.05; text modified on 1.01.13)*

### § 2 UCI Rankings

#### 8.4.003 A classification for cycle-ball teams playing in the highest national leagues shall be set up.

The UCI shall be the sole owner of these classifications.

*(article introduced on 1.01.05)*

#### 8.4.004 The classifications shall be published on 30 June, 30 September, 30 November and 31 December.

*(article introduced on 1.01.05)*

#### 8.4.005 National federations and organizers are required to send full results to the UCI immediately by fax.

Any national federation must immediately notify the UCI of any fact or decision resulting in an alteration to the points scored.

In the event of a failure to do so, the UCI Management Committee may downgrade the event in question or exclude it from the calendar, without prejudice to other penalties applicable under the regulations.

*(article introduced on 1.01.05; text modified on 1.01.13)*

**8.4.006** Points scale

Place	<i>World Championships</i>	UCI A Events, World Cup	Continental Championships and cups	UCI B Events, National Championships
1	60	50	40	30
2	55	45	35	25
3	50	40	30	20
4	45	35	25	18
5	40	30	20	16
6	35	25	18	14
7	32	20	16	12
8	29	18	14	10
9	26	16	12	8
10	23	14	10	6
11	20	12	8	
12	18	10	6	
13	16	8	4	
14	14	6	2	
15	12	4	1	
16	10			
17	9			
18	8			
19	7			
20	6			
21	5			
22	4			
23	3			
24	2			
25	1			

*(text modified on 1.01.05)*

**Chapter V WORLD CHAMPIONSHIPS SET UP**

**8.5.001** Split up of leagues

Number of teams	12	13	14	15	16	17	18	19	20	21
<b>A league</b>	6	6	6	6	6	6	6	6	6	6
1 <sup>st</sup> round	15	15	15	15	15	15	15	15	15	15
2 <sup>nd</sup> round	2	2	2	2	2	2	2	2	2	2
3 <sup>rd</sup> round	2	2	2	2	2	2	2	2	2	2
Final	1	1	1	1	1	1	1	1	1	1
<b>Total</b>	<b>20</b>	<b>20</b>	<b>20</b>	<b>20</b>	<b>20</b>	<b>20</b>	<b>20</b>	<b>20</b>	<b>20</b>	<b>20</b>
<b>B league 1</b>	6	7	4	5	5	6	6	5	6	5
1 <sup>st</sup> round	<b>15</b>	<b>21</b>	<b>6</b>	<b>10</b>	<b>10</b>	<b>15</b>	<b>15</b>	<b>10</b>	<b>15</b>	<b>10</b>
<b>B league 2</b>			4	4	5					
1 <sup>st</sup> round			6	6	10					
B league ranking			4	4	5					
<b>C league 1</b>						5	6	4	4	5
1 <sup>st</sup> round						<b>10</b>	<b>15</b>	<b>6</b>	<b>6</b>	<b>10</b>
<b>C league 2</b>								4	4	5
1 <sup>st</sup> round								<b>6</b>	<b>6</b>	<b>10</b>
Ranking								4	4	5
Promotion						1	1	1	1	1
<b>Grand total</b>	<b>36</b>	<b>42</b>	<b>37</b>	<b>41</b>	<b>46</b>	<b>47</b>	<b>52</b>	<b>48</b>	<b>53</b>	<b>57</b>
Commissaires	6	6	6	6	6	6	7	7	7	7
Games / Commissaire Chief not included	6	6	6.2	7	7.7	7.8	7.5	7	7.5	8.1

*(article introduced on 1.01.13)*

**8.5.002** *World Championships mode*

New mode: valid as from 2015 UCI Indoor Cycling *World Championships*

1 <sup>st</sup> round	2 <sup>nd</sup> round	3 <sup>rd</sup> round	1 <sup>st</sup> half-final	2 <sup>nd</sup> half-final	Match 3 <sup>rd</sup> place	Final
1.				Winners 1 <sup>st</sup> round	Losers 1 <sup>st</sup> half-final	Winners 1 <sup>st</sup> half-final
2.	2 <sup>nd</sup> – 5 <sup>th</sup>	Losers match 2.	Winners match 2.			
3.	3 <sup>rd</sup> – 4 <sup>th</sup>	against	against	against	against	against
4.		Losers match 3.	Winners match 3.			
5.				Lucky looser	Losers 2 <sup>nd</sup> half-final	Winners 2 <sup>nd</sup> half-final
6.						
		Lucky looser > 2 <sup>nd</sup> half-final	Winners > Final	Winners > Final		
			Losers > match for the 3 <sup>rd</sup> place	Losers > match for the 3 <sup>rd</sup> place		
	* Penalty shooting	* Penalty shooting	* Penalty shooting	* Penalty shooting	* overtime then penalty shooting	* overtime then penalty shooting

\* Decision in case of a draw